



Idola S Hybrid C

Air-water reversible heat pumps in R32 for split installation with instant production of DHW

- The **IDOLA S HYBRID C 3.2** hybrid heat pumps combine **R32 eco-friendly heat pump technology** and the **condensation boiler** with the instant production of DHW in a single compact product.
- The eco-friendly **R32** gas combines high efficiency with a reduced environmental impact. Thanks to its **GWP of 675**, about a third compared to the GWP of R410a, it helps to reduce emissions of CO₂, which are the main cause of global warming.
- Lamborghini CaloreClima hybrid systems are the **ideal solution for replacing old existing boilers, even on high-temperature systems with radiators**, thanks to the integration of the boiler.
- The compact size, similar to that of a wall-hung boiler, **makes it easier to replace without significant loss of space** or the need for major restructuring work.
- **By running the boiler** or heat pump as the climatic conditions vary, the internal electronics **optimise the output of the system** by constantly operating **in the most economic and efficient mode possible**, with excellent benefits for the end user.
- The boiler will be free to **produce instant DHW** even during heat pump heating or cooling operations, thereby **maximising the comfort levels**. In the unlikely event that the heat pump is blocked, the boiler will still be able to operate autonomously in backup mode, **thus guaranteeing heating and the production of DHW**.
- The system consists of a **Full DC inverter external unit**, available with a choice of 4 different powers, **associated with the hybrid internal and condensation unit with an integrated hydronic module, including a DC inverter pump** to manage the cooling circuit. The system is **extremely versatile** and capable of operating in **harsh climate conditions up to -20°C outdoors**. It **avoids the risk of freezing** thanks to a split cooling circuit.
- Wall flue gas exhaust in the cases pertaining to Italian Leg. Decree no. 102 of 4 July 2014.

FEATURES OF THE EXTERNAL UNIT:

- Approved for external use in completely exposed site
- Powered by R32 eco-friendly gas with low environmental impact
- Inrush current and reduced noise thanks to Full Inverter technology
- Compressor with twin rotary DC INVERTER motor on vibration damping supports and wrapped in double layer of soundproofing material to minimise vibrations and noise.
- Axial fans with DC brushless motor including protective grilles
- Outdoor air temperature probe pre-installed on the unit.

FEATURES OF THE INTERNAL UNIT:

- Sturdy and suitable for replacements even in particularly critical systems.
- Combustion module with a 1:10 modulation range and extra-thick stainless steel heat exchanger with larger channels to maintain high efficiency even on old oxidised and soiled systems
- Standard supply with squared system supply and return valves (with easy-access filter for inspection)
- **M.G.R: Methane, LPG, Propane-air Ready**, with a simple configuration, the boiler can run on natural gas, LPG and a propane-air mixture without the use of any additional conversion kits
- **MC²: Multi Combustion Control**, combustion system with patented gas-adaptive technology for improved adaptability of use to variations in the gas supply conditions (e.g. pressure fluctuations or drops)
- **F.P.S: Flue gas protection system**. The standard flue gas check valve offers easy connection to pressurised collective flue systems
- **Particularly suited to operating in flues requiring "heavy-duty" pipes** thanks to approval for **operation with flue gas exhaust pipes with a diameter of 50mm**
- **Installation site:** also for outdoor use in partially protected areas up to -5°C as standard.

ECO-FRIENDLY REFRIGERANT GAS R32

R32

New Heat Pump with R32, an eco-friendly refrigerant gas with a low GWP.

Up to 75% less CO₂ equivalent emissions into the environment compared to an R410a machine.

System code	System model
OXHK4GWD	IDOLA S HYBRID C 3.2 04
OXHK6GWD	IDOLA S HYBRID C 3.2 06
OXHK8GWD	IDOLA S HYBRID C 3.2 08 (*)
OXHK8EWD	
OXHKAGWD	IDOLA S HYBRID C 3.2 10

(*) The code will be confirmed during the order phase based on the commercial back office availability

THE CONTROL SYSTEM

- The interface features **Capsense** technology with a 2.8" graphic display for user-friendly, practical interaction. The on-board machine interface communicates seamlessly with the new **Connect CRP** smart systems, which can control **up to 8 thermostats** (of which 7 are **Connect CRP Zones**), divided into 2 zones, one direct and one mixed.
- **MODBUS PROTOCOL** for smart control via an external BMS
- **HEATING AND COOLING** with Lamborghini CaloreClima's Full Inverter modulation which allows you to set the temperature curve to reduce consumption and improve user comfort.
- **SMART GRID INPUT FROM PHOTOVOLTAIC SYSTEM AND POWER GRID** Smart Grid contacts to optimise consumption and save on energy bills. Consult the manuals for more details
- **REMOTE CONTROL VIA APP** Available for iOS and Android using the Connect CRP (optional)
- **SILENT PDC MODE**. Reduces the maximum compressor frequency and fan speed, thus significantly reducing noise levels.
- **ON/OFF and SUMMER/WINTER** from external contacts. The unit can be switched on and off via an external contact, by receiving summer/winter switching signals (e.g. from the zone thermostat). The operating mode will follow the controller settings
- **ECO** Dedicated setpoint for "Eco" mode. Can be set with a daily time slot
- **WEEKLY HOURLY PROGRAMMING**. The Connect CRP (optional) allows differentiated hourly programming for each day of the week, defining the mode (COOL/WARM/DHW) and operating setpoints for each time slot.

IDOLA S 3.2 HY C		04	06	08	10
ERP class in heating / Seasonal efficiency average temperature (produced water 35°C)	Class / ηs (%)	A+++ 186	A+++ 191	A+++ 200	A+++ 201
ERP class in heating / Seasonal efficiency low temperature (produced water 55°C)	Class / ηs (%)	A++ 128	A++ 136	A++ 130	A++ 135
SCOP (low temperature 35°C)	W/W	4.85	4.95	5.21	5.19
SEER (produced water 7°C)	W/W	4.99	5.34	5.83	5.98
Power supply	V-ph-Hz	220/240-1-50			
Type and no. of compressors	-	1 x Twin Rotary DC			
Type of exchanger system side / source side	-	brazed stainless steel plates / finned coil			
Type of fans / no. of fans	-	brushless DC / 1			
Refrigerant fittings - liquid line	Ø	1/4" SAE / Ø 6.35		3/8" SAE / Ø 9.52	
Refrigerant fittings - gas line	Ø	5/8" SAE / Ø 15.88			
Indoor unit expansion vessel volume	L	8			
SWL - outdoor* / indoor* unit sound power level	dB(A)	56 / 39	58 / 39	59 / 39	60 / 39
Outdoor / indoor unit weight	kg	58 / 43		77 / 43	

NOTE: Efficiency class calculated according to the European regulation 811/2013. The values refer to a unit without any optionals or accessories. * **SWL** = Sound power level, for 1x10⁻¹² W with unit functioning in **A7W35** conditions. The Total sound power level in dB(A) is measured in accordance with standard ISO 9614. The Total Sound Power in dB(A) which is, therefore, the only demanding acoustic data. The sound pressure levels are values calculated from the sound power level (SWL) applying the ISO-3744 relationship.

PERFORMANCE DATA		04	06	08	10	
A7W35	Nominal heat output	kW	4.20	6.35	8.40	10.0
	Nominal input power	kW	0.82	1.28	1.63	2.02
	COP	W/W	5.10	4.95	5.15	4.95
A7W45	Nominal heat output	kW	4.30	6.30	8.30	10.0
	Nominal input power	kW	1.13	1.70	2.16	2.67
	COP	W/W	3.80	3.70	3.85	3.75
A35W18	Designed cooling capacity	kW	4.50	6.50	8.30	9.90
	Nominal input power	kW	0.82	1.35	1.64	2.18
	EER	W/W	5.50	4.80	5.05	4.55
A35W7	Designed cooling capacity	kW	4.70	6.50	7.45	8.20
	Nominal input power	kW	1.36	2.17	2.22	2.52
	EER	W/W	3.45	3.00	3.35	3.25

The values refer to a unit without any optionals or accessories. Data declared according to **EN 14511**: **EER** (Energy Efficiency Ratio) = ratio of cooling power to input power **COP** (Coefficient Of Performance) = ratio of heat output to input power **A7W35** = source: air in 7°C d.b. 6°C w.b. / system: water in 30°C out 35°C **A7W45** = source: air in 7°C d.b. 6°C w.b. / system: water in 40°C out 45°C **A35W18** = source: air in 35°C d.b. / system: water in 23°C out 18°C **A35W7** = source: air in 35°C d.b. / system: water in 12°C out 7°C **NOTES:** Efficiency class calculated according to the European regulation **811/2013**.

INDOLA S 3.2 HY C PERFORMANCE		04	06	08	10
Max/min thermal output in heating (Hi)	kW	24.5 / 2.9			
Max/min thermal output in heating (80/60°C)	kW	24 / 2.8			
Max/min thermal output in heating (50/30°C)	kW	26 / 3.1			
Max/min thermal output in DHW (Hi)	kW	28.5 / 3.2			
Max/min thermal output in DHW	kW	28.0 / 2.8			
Pmax/Pmin efficiency (80-60°C) (Hi)	%	98.1 / 98			
Pmax/Pmin efficiency (50-30°C) (Hi)	%	106.1 / 107.5			
Efficiency 30% (Hi)	%	109.7			
Max/min working pressure in heating	bar	3 / 0.8			
Max/min working pressure in DHW	bar	9 / 0.3			
DHW flow rate Δt 25°C / 30°C	l/min	16.1 / 13.4			

OPTIONAL ACCESSORIES	DESCRIPTION
046053X0	Galvanised normal template
012050W0	Hydraulic kit with: gas tap, water inlet tap and connection pipes/fittings
016009X0	Attachment cover kit for aesthetic cover of wall-mounted hydraulic connections
013054XD	Connect CRP
013055XD	Connect CRP Zones

OPTIONAL ACCESSORIES	DESCRIPTION
041083X0	Coupling for vertical coaxial pipe ø 100/60 mm for condensation boilers
041006X0	Coupling for vertical coaxial pipe ø 80/125 mm for condensation boilers
041084X0	90° coaxial bend, 360° swivel with 45° pitch ø 100/60 mm for condensation boilers
041082X0	Twin pipe 80/80 discharge kit for condensation boilers, including test points
2CP000ZF	Rubber anti-vibration kit for outdoor unit
2CP000NF	System flow temperature probe or for hybrid solar/ hybrid system integration

Operational limits

COOL MODE

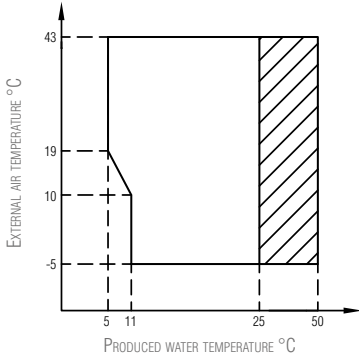

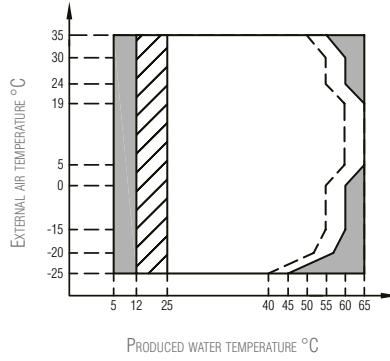

 Operating range with heat pump with possible limitation and protection

WARM MODE



 Operating range with heat pump with possible limitation and protection

 With IBH (internal backup heater) installed

 Maximum inlet water temperature for heat pump operation

Minimum working spaces (in mm)

INDOOR UNIT

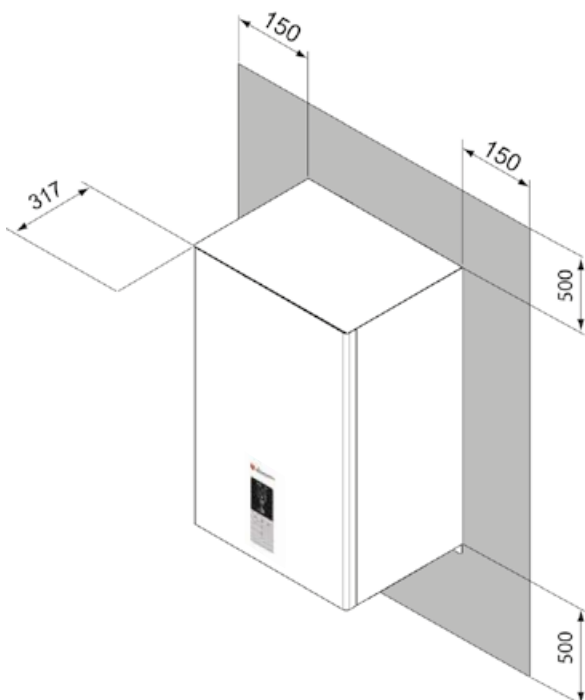

OUTDOOR UNIT

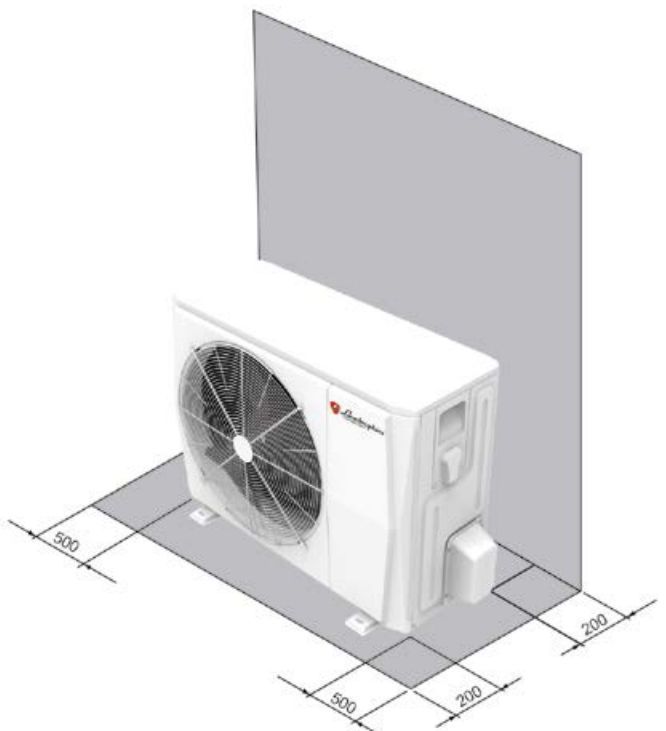

Overall dimensions of outdoor unit (in mm)

mod. 4 - 6

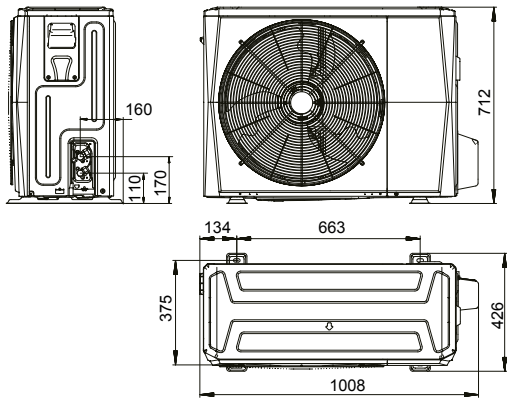

mod. 8 - 10

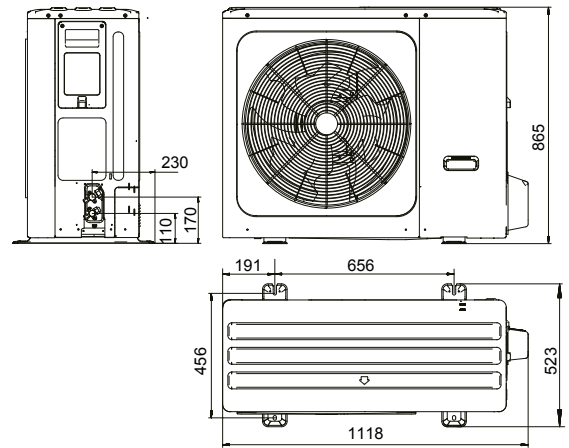

MODELS		4	6	8	10
Packaging (WxHxD)	mm	1065x800x485		1190x970x560	
Packaging weight	kg	65		94	

Overall dimensions of indoor unit (in mm)

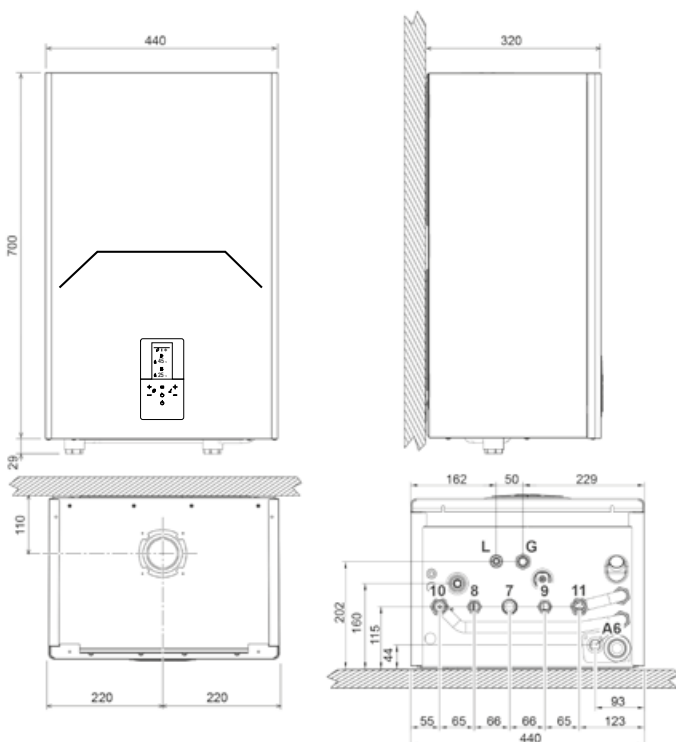

LEGEND

- 7 Gas inlet - Ø 3/4"
- 8 DHW outlet - Ø 1/2"
- 9 DHW inlet - Ø 1/2"
- 10 System delivery - Ø 3/4"
- 11 System return - Ø 3/4"
- A6 Condensate drain connection
- L Liquid line
- G Gas line